

HOW TO USE BANDSAW MACHINES

The sawing machine is a machine tool designed to cut material to a desired length or contour. It functions by drawing a blade containing cutting teeth through the workpiece. The sawing machine is faster and easier than hand sawing and is used principally to produce an accurate square or mitered cut on the workpiece.

The power hacksaw and the bandsaw are two common types of sawing machines used to cut metal in the machine shop. The power hacksaw uses a reciprocating (back and forth) cutting action similar to the one used in a hand hacksaw. The power hacksaw is used for square or angle cutting of stock.

The powered band saw uses a continuous band blade. A drive wheel and an idler wheel support and drive the blade. If horizontal type; the blade is lowered onto the material to be cut. If it is a vertical bandsaw, the piece is fed into the blade.

BANDSAW MACHINES

Metal-cutting bandsaw machines fall into two basic categories: vertical machines ([Figure 6-2](#)) and horizontal machines ([Figure 6-3](#)). Band saws use a continuous saw blade. Chip removal is rapid, because each tooth is a precision cutting tool and accuracy can be held to close tolerances eliminating or minimizing many secondary machining operations.

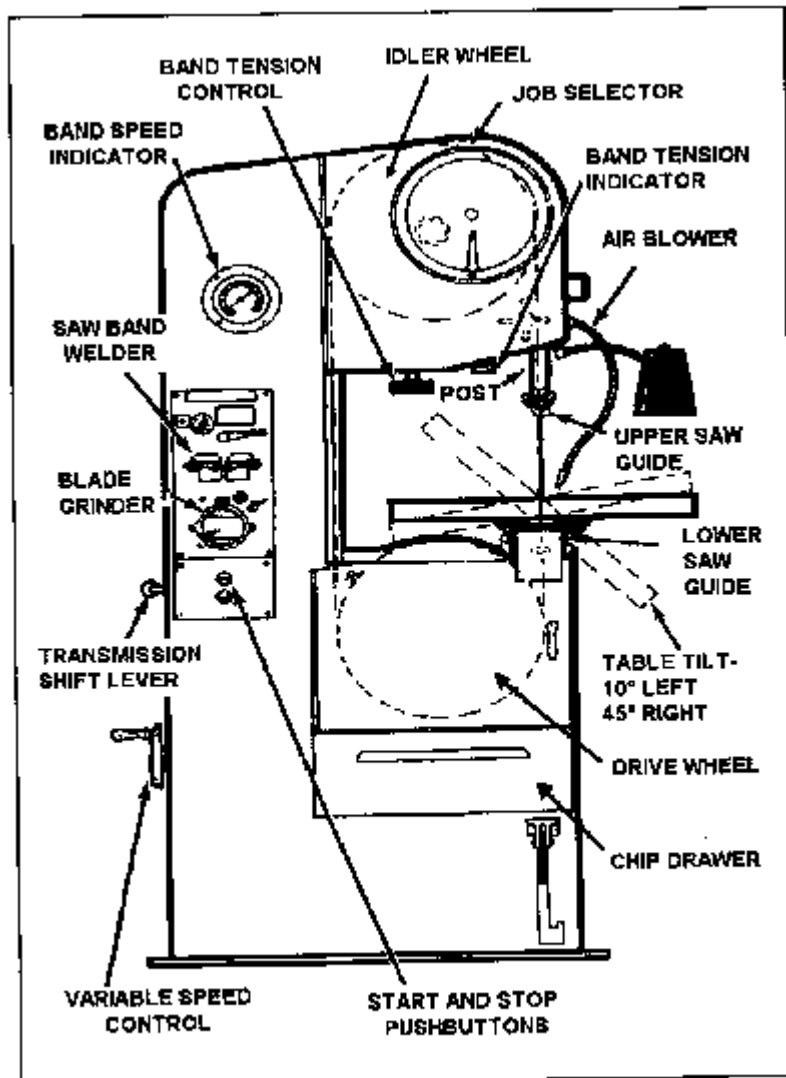
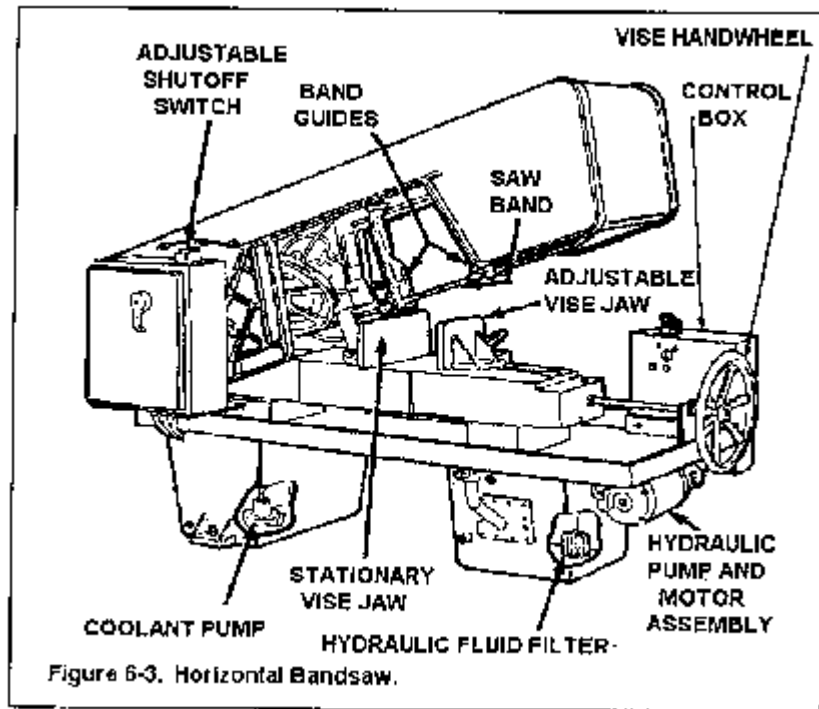

Figure 6-2. Vertical band sawing machine.



VERTICAL BANDSAWING MACHINE

The metal-cutting vertical band sawing machine, also called a contour machine, is made in a variety of sizes and models by several manufacturers. The size of a contour machine is determined by the throat depth, which is the distance from the saw band to the column. [Figure 6-2](#) shows a typical contour machine and identifies its main parts, which are discussed below.

- The head is the large unit at the top of the contour machine that contains the saw band idler wheel, the drive motor switch, the tension adjustment handwheel and mechanism, a flexible air line (directs a jet of air at the work to keep layout lines free from chips), and the adjustable post which supports the upper saw guide. The job selector dial is also located on the head.
- The column contains the speed indicator dial, which is driven by a cable from the transmission and indicates the speed in feet per minute (FPM). The butt welder is also mounted on the column.
- The base contains the saw band drive wheel, the motor, and the transmission. The transmission has two speed ranges. The low range gives speeds from 50 FPM to 375 FPM. The high range gives speeds from 260 FPM to 1,500 FPM. A shift lever on the back of the base can be placed in the high, low, or neutral position. Low is recommended for all speeds under 275 FPM. The base also supports the table and contains the lower saw band guide, which is mounted immediately under the table slot. The power feed mechanism is located within the base, and the feed adjustment handle and foot pedal are located on the front of the base.

VARIABLE SPEED UNIT

The variable speed unit is located within the base of the machine. This unit consists of two V-type pulleys which are mounted on a common bearing tube. A belt on one pulley is driven by the transmission, while the belt on the other pulley drives the saw band drive wheel. The two outside cones of the pulleys are fixed, but the middle cone is shifted when the speed change wheel is turned. A shift in the middle cone causes the diameter of one pulley to increase and the diameter of the other pulley to decrease. This slowly changes the ratio between the two pulleys and permits a gradual increase or decrease in the speed of the machine.

HORIZONTAL BANDSAW MACHINE

The horizontal band sawing machine does the same job as the power hacksaw but does it more efficiently. The blade of the bandsaw is actually a continuous band which revolves around a drive wheel and idler wheel in the band support frame. Two band guides use rollers to twist the band so that the teeth are in the proper cutting position. The guides are adjustable and should be adjusted so that they are just slightly further apart than the width of the material to be cut. This will give maximum support to the saw band and help assure a straight cut.

The vise on the horizontal bandsaw is much like the one on the power hacksaw. However, the horizontal bandsaw has a much greater capacity for large stock than does the power hacksaw. The stationary jaw can be set at several angles. The movable jaw adjusts automatically to whatever position the stationary jaw is in when the vise handwheel is tightened.

The horizontal bandsaw is operated hydraulically by controls on a control box, which is located on the front side of the machine. A motor and pump assembly supplies hydraulic fluid from a reservoir in the base to a cylinder, which raises and lowers the support arm and also controls the feed pressure and band tension. A speed and feed chart is sometimes provided on the machine, but when it is not, consult the operator's manual for the proper settings for sawing.

A coolant pump is located in one of the legs of the base, which serves as a coolant reservoir. The coolant cools the saw band and also washes away chips from the cut before they can clog the band.

SAFETY PRECAUTIONS

Sawing machines have some special safety precautions that must be observed. These are in addition to those safety precautions described in [Chapter 1](#). Here are some safety precautions that must be followed:

- Keep hands away from the saw blade of the hacksawing machine or bandsawing machine when in operation.
- Ensure the power supply is disconnected prior to removal or installation of saw blades.
- Use a miter guide attachment, work-holding jaw device, or a wooden block for pushing metal workpieces into the blade of the bandsaw wherever possible. Keep fingers well clear of the blade at all times.
- When removing and installing band saw blades, handle the blades carefully. A large springy blade can be dangerous if the operator does not exercise caution.

TOOLS AND EQUIPMENT

POWER HACKSAW BLADES

Power hacksaw blades differ from hand hacksaw blades in that they are generally heavier, made in longer sizes, and have fewer teeth per inch. Hacksaw blades are discarded when they become dull; sharpening is not practical.

Materials commonly used in manufacturing power hacksaw blades are high-speed tungsten steel and high-speed molybdenum steel. On some blades only the teeth are hardened, leaving the body of the blade flexible. Other blades are hardened throughout.

The set is the amount of bend given the teeth. The set makes it possible for a saw to cut a kerf or slot wider than the thickness of the band back (gage), thus providing side clearance.

This is the pattern in which the teeth are set. There are three set patterns: raker, wave, and straight, as shown in [Figure 6-4](#).

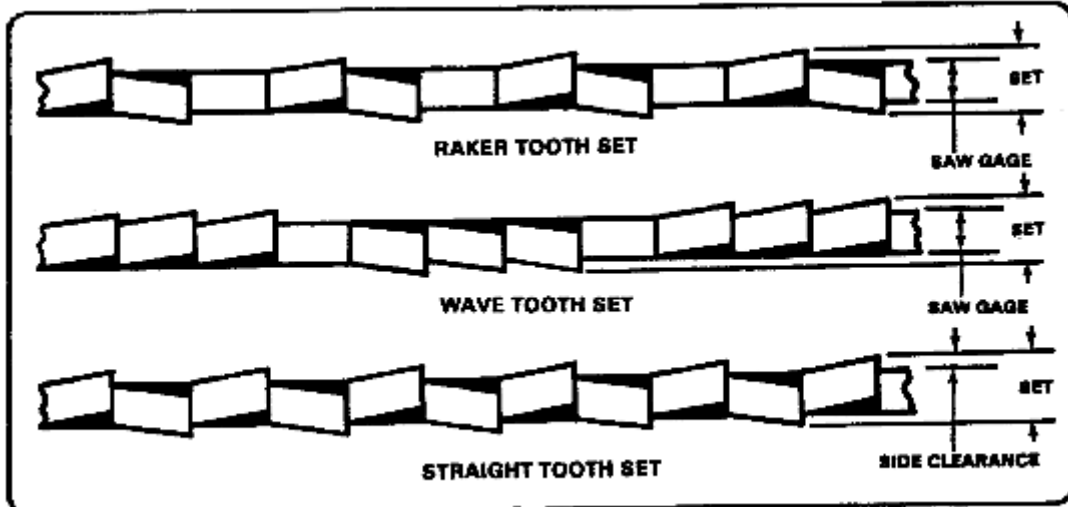

Figure 6-4. Set pattern.

The pitch of hacksaw blade teeth (Figure 6-5) is expressed as the number of teeth per linear inch of blade. For example, a blade having 10 teeth per inch is said to be 10 pitch.

MATERIAL	HACKSAW BLADE TEETH PER INCH (PITCH)
SHEET METAL	14
SOLID STOCK: 1	
ALUMINUM	4
BRASS	10
BRONZE	4
CAST IRON	4
COPPER	4
STEEL, ALLOY	6
STEEL, HIGH-SPEED	6
STEEL, MACHINE	4
STEEL, STAINLESS	6
STEEL, TOOL (ANNEALED)	6
STEEL, TOOL (UNANNEALED)	4
TUBING, THIN	14
TUBING, HEAVY	10

1. Three or more teeth must contact the workpiece at all times to prevent blade damage. If the recommended pitch for a material fails to meet this requirement, a blade with more teeth to the inch should be used.

Figure 6-5. Selection of power hacksaw blades.

Power hacksaw blades are coarser in pitch (fewer teeth per inch) than hand hacksaw blades. Common pitches for power hacksaw blades range from 4 to 14 teeth per inch.

The following are guidelines for the selection of power hacksaw blades.

- Select power hacksaw blades for material to be cut.
- Soft materials require a coarser blade to provide adequate spaces between the teeth for removal of chips. Hard material requires a finer blade to distribute the cutting pressure to a greater number of teeth, thereby reducing wear to the blade.
- At least three teeth must be in contact with the workpiece at all times or the blade will snag on the workpiece and break teeth from the blade. Therefore, a blade must be selected with sufficient pitch so that three or more teeth will be in contact with the workpiece, no matter what type of material is being cut.

[Figure 6-5](#) is provided to assist in the proper selection of power hacksaw blades. Note that sheet metal and tubing are listed separately from solid stock. It is assumed that solid stock will be sufficiently thick that three or more teeth will be in contact with the stock at all times.

BANDSAW BLADES

General

Bandsaw blades are manufactured in two forms. They are supplied in rolls of 50 to 500 feet for use on machines that have butt welders for forming their own blade bands. Bandsaw blades are also supplied in continuous welded bands for machines having no provisions for welding.

Materials

Bandsaw blades are made from special alloy steels. The blades are made flexible by annealing the body of the blade and hardening only the teeth.

Set

Metal cutting bandsaw blades have their teeth bent ([Figure 6-4](#)). This bend produces a kerf slightly wider than the thickness of the blade, which prevents the blade from being pinched by the stock. There are three set patterns: raker, wave, and straight, as shown in [Figure 6-4](#).

Pitch

The pitch of bandsaw blades is expressed as the number of teeth per linear inch of the blade. Metal cutting blades range from 6 to 32 teeth per inch, the coarser tooth blades being used for sawing large stock and soft metals.

Selection of Bandsaw Blades

Select bandsaw blades according to the type of material to be cut, the thickness of the material to be cut, and the sawing operation to be performed. Always use the widest and thickest saw band possible. However, consider the curvature of the cut, since wide saw blades cannot cut sharp curves. [Figure 6-6](#) shows saw band selection for various radii.

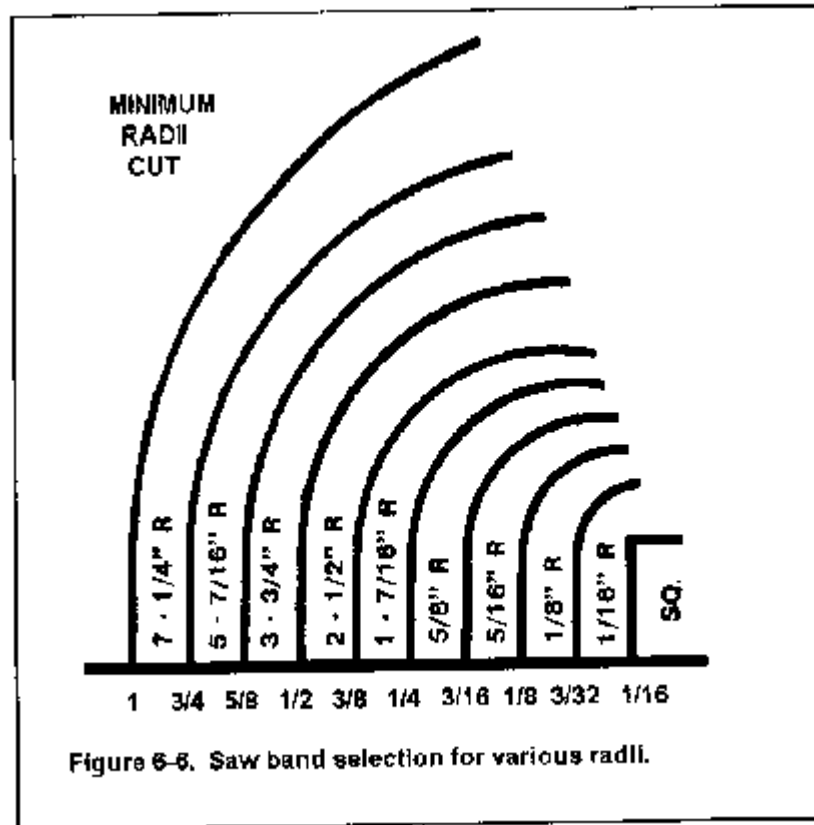

For general sawing, use the raker set pattern. The wave set pattern is used where thin work sections are encountered during the cut, such as tubing, angles, and channels.

Three teeth of the bandsaw blade must be in contact with the workpiece at all times to prevent chatter and shearing off teeth. Therefore, use fine tooth blades to cut sheet metal and tubing. If the sheet metal is too thin to meet this requirement with the finest tooth blade available, place the metal between plywood, fiberboard, or thicker metal. [Figure 6-7](#) is a guide for selecting the proper pitch band saw blade for different metals and metal thickness.

MATERIAL	BANDSAW BLADE (TPI)	MATERIAL	BANDSAW BLADE (TPI)
SHEET METAL UNDER 1/8 INCH THICK	24-32	SOLID STOCK CONTINUED	
SHEET METAL OVER 1/8 INCH THICK	18	STEEL, ALLOY	12-14
SOLID STOCK: 1		STEEL, HIGH-SPEED	12-14
ALUMINUM	6-10	STEEL, MACHINE	10-14
BRASS	10-12	STEEL, STAINLESS	12-14
BRONZE	12-14	STEEL, TOOL	12-14
CAST IRON	10-12	TUBING UNDER 1/8-INCH WALL THICKNESS	24-32
COPPER	10-12	TUBING OVER 1/8-INCH WALL THICKNESS	18

1. Three or more teeth must contact the workpiece at all times to prevent shearing of the blade teeth. If the recommended pitch for solid stock fails to meet this requirement, a blade with finer pitch must be selected.

Figure 6-7. Selection of band saw blades.

The finish depends largely upon the saw pitch. The faster the saw speed and the finer the sawpitch, the finer the finish. Lubricating helps to improve the finish. A fine saw pitch, high velocity, and light feed produce the finest finish.

Bandsaw Blade Wear

Bandsaw blades naturally become dull from prolonged use, but some conditions promote greater than normal wear on the blades. Blades dull quickly if used at too high a speed for the material being cut. Also, if the material to be cut is too hard for the pitch of the blade, abnormal wear will result. The most common cause of premature blade dulling occurs from using too fine a pitch blade and from feeding too heavily.

The following symptoms indicate a dull bandsaw blade. When these symptoms are noticed, the blade should be replaced.

- It becomes difficult to follow a line, the blade being forced to one side or the other.
- The chips are granular (except for cast iron, which produces granular chips with both sharp and dull blades).
- The bandsaw blade cuts slowly or not at all when the workpiece is fed by hand.
- With the machine stopped or the bandsaw blade removed, run a finger slowly over the teeth in the cutting direction. If sharp edges are not felt the blade is dull.

FILE BANDS

The bandsawing machine is adapted for filing by use of the band file attachment. A band file is fitted over the drive and idler wheels and in place of the bandsaw blade. The band is made up of several parts or segments which are riveted at one end (the leading end) to a spring steel band. The trailing end of each segment is free to lift during the time when the band bends over the drive and idler wheels of the band saw. When the band straightens out, the segments lock together. [Figure 6-8](#) shows the construction of and terminology for file band parts.

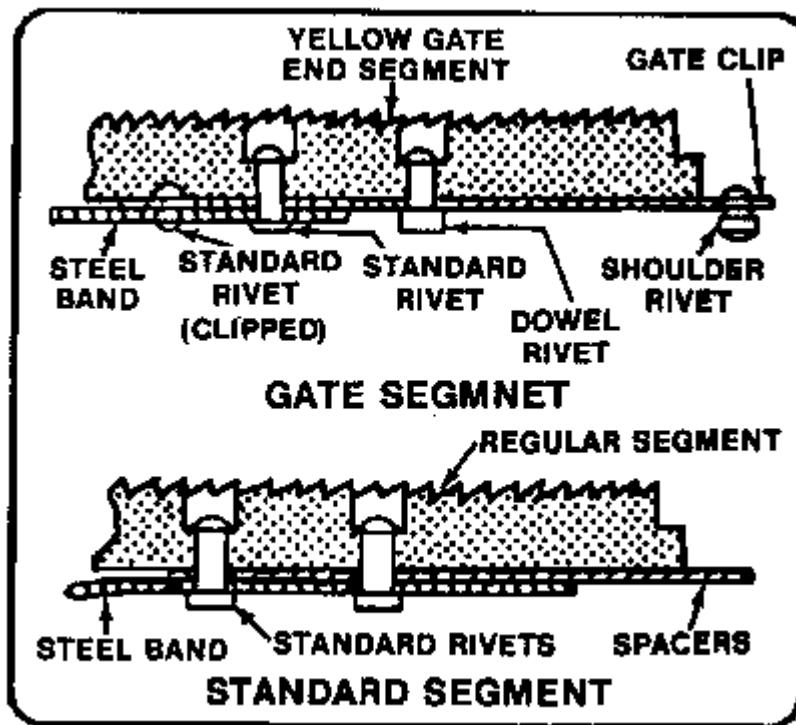

Figure 6-8. Construction and parts of a file band.

Note that the gate segment (a segment at one end of the band that is specially designed to allow the two band ends to be locked together) has a shoulder rivet and a dowel rivet protruding from beneath it. The shoulder rivet locks into the other file band end, and the dowel rivet aligns the two end segments and prevents the shoulder rivet from sliding out of the locked position during filing. The gate segment of a file band is identified by yellow paint.

Cut of File Teeth

File bands are either coarse or bastard cut and normally range in pitch from 10 to 20 teeth per inch. The coarse 10-pitch bands are used for filing softer metals such as aluminum, brass, copper, and cast iron. A bastard-cut 14-pitch band is a good choice for general steel filing, while 16 to 20 pitch bastards are recommended for filing tool steel.

Selection of Band Files

Choose band files on the basis of workpiece thickness and type of material to be filed. In general, the thicker the workpiece, the coarser the file should be. This is due to a larger chip accumulation from the larger area of the workpiece, thus requiring additional space for the chips between the teeth. On thin sheet metal, a fine pitch file is required to prevent chatter. Use fine pitch files for filing tough carbon and alloy steels; use coarser pitch files for filing softer metals. [Figure 6-9](#) is provided to aid in selecting the proper file for filing specific materials.

BAND FILE		
MATERIAL	CUT OF TEETH	TEETH PER INCH
ALUMINUM	SHORT ANGLE OR BASTARD-CUT	10-12
BRASS	SHORT ANGLE OR BASTARD-CUT	10-12
BRONZE	SHORT ANGLE OR BASTARD-CUT	10-12
CAST IRON	SHORT ANGLE OR BASTARD-CUT	10-12
COPPER	SHORT ANGLE OR BASTARD-CUT	10-12
FIBER	SHORT ANGLE OR BASTARD-CUT	10-12
MAGNESIUM	SHORT ANGLE OR BASTARD-CUT	10-12
STEEL, ALLOY	BASTARD-CUT	14-24
STEEL, MACHINE	BASTARD-CUT	14-16
STEEL TOOL	BASTARD-CUT	14-24

Figure 6-8. Selection of band files.

Care and Cleaning of Band Files

Clean the file often, using a stiff brush or a file card. Move the brush in the direction of each cut of the file to dislodge all particles hidden between the teeth.

The file band should not be coiled into more than three loops. The best means of storing file bands is in a cabinet looped over a 16-inch radius support with the ends hanging free.

Band File Attachment

A band file attachment ([Figure 6-10](#)) is provided with most bandsaw machines to permit the use of band files. A typical band file attachment consists of a band file guide and upper and lower guide supports that attach to the frame and part of the band saw. A special filing filler plate is provided to adapt the table slot to the extra width and depth required for the band file and file band guide.

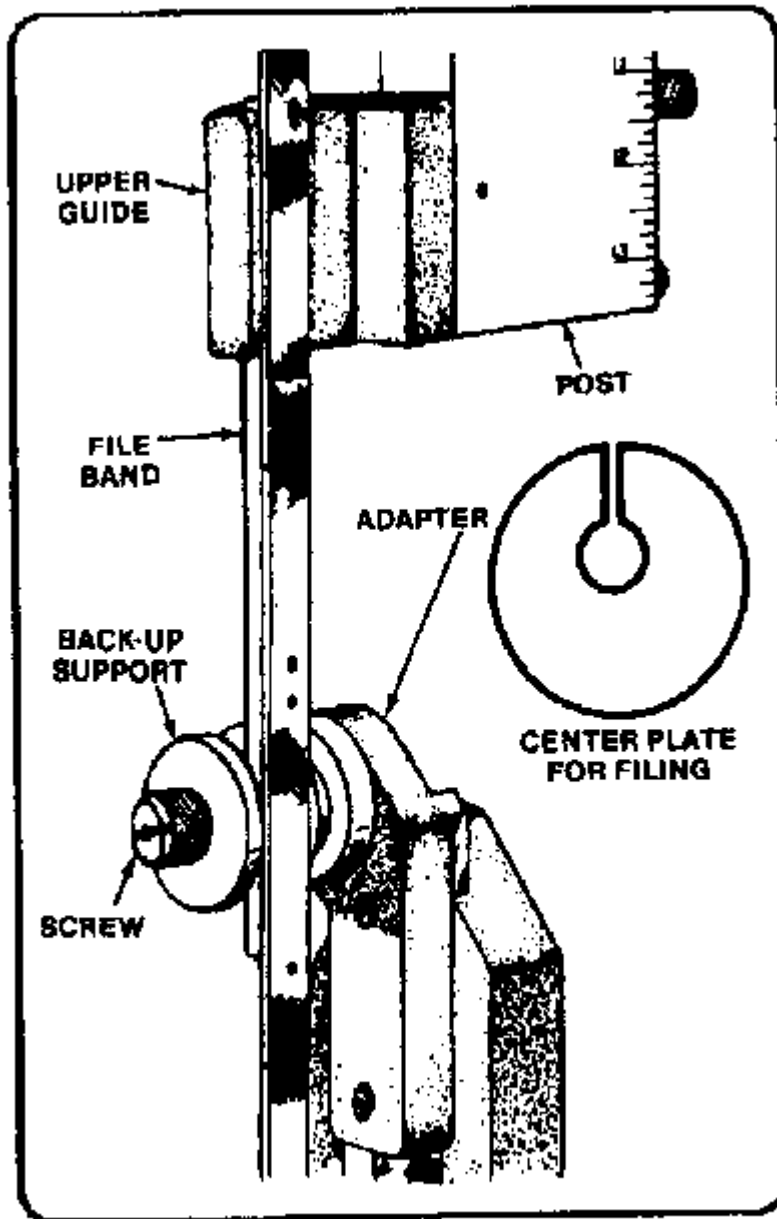

Figure 8-10. Band file attachment installed on bandsawing machine.

POLISHING BANDS

Polishing can be performed on the bandsaw using a polishing attachment and polishing band. The polishing band is usually 1 inch wide and has a heavy fabric backing.

Types of Polishing Bands

Polishing bands for bandsawing machines are usually supplied in various grain sizes of aluminum-oxide or silicone carbide abrasive: No 50 grain (coarse) for heavy stock removal and soft material, No 80 (medium) for general surface finishing, and No 120 or No 150 grain (fine) for high polishing and light stock removal.

Selection of Polishing Bands

Polishing bands should be selected according to the particular job to be performed. For removing tool marks and deburring edges, use the No 50 grain polishing band. Finer grain polishing bands should not be used on soft metals like aluminum or cast iron because the band will quickly fill with metal particles, reducing the cutting action

Polishing Attachment

The polishing attachment ([Figure 6-11](#)), similar to the band file attachment, provides support for the polishing band. The polishing band plate acts as a solid backing for the polishing band to prevent stretching and distorting the band when the workpiece is held against it. Use a polishing band filler plate to fill the table slot so the workpiece can be supported close to the polishing band.

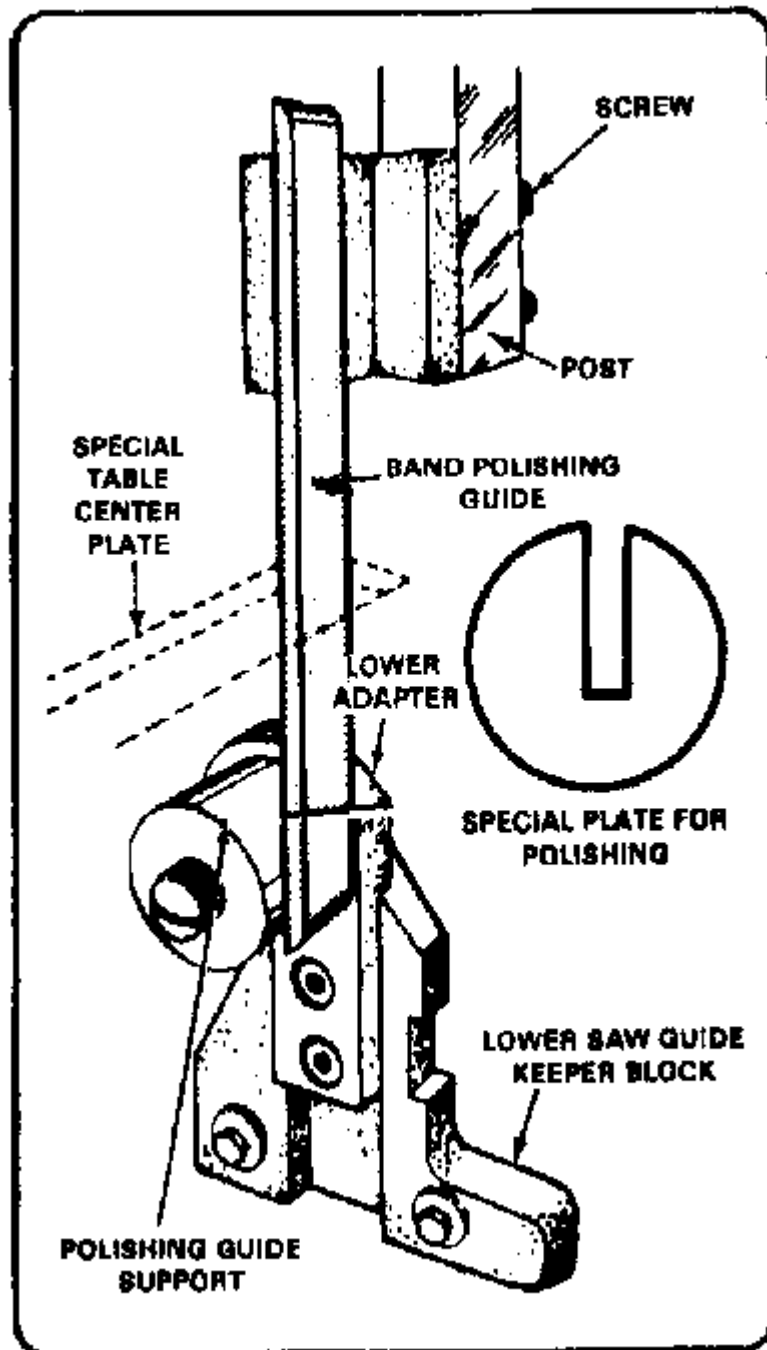

Figure 6-11. Polishing attachment installed on bandsawing machine.

DISC-CUTTING ATTACHMENT

Use the disc-cutting attachment ([Figure 6-12](#)) to saw internal or external circles and discs. The diameter of the circle that can be cut is limited to the length of the cylindrical bar on the attachment or to the throat depth of the machine. The disc-cutting attachment consists of three main parts a clamp and cylindrical bar, which is fastened to the saw guidepost; an adjustable arm, which slides on the cylindrical bar; and a pivot or centering pin. The disc must be laid out and center-drilled to a depth of 1/8 inch to 3/16 inch to provide a pivot point for the centering pin. The centerline of the centering pin must be in line with the front edge of the sawteeth and at the desired distance from the saw band.

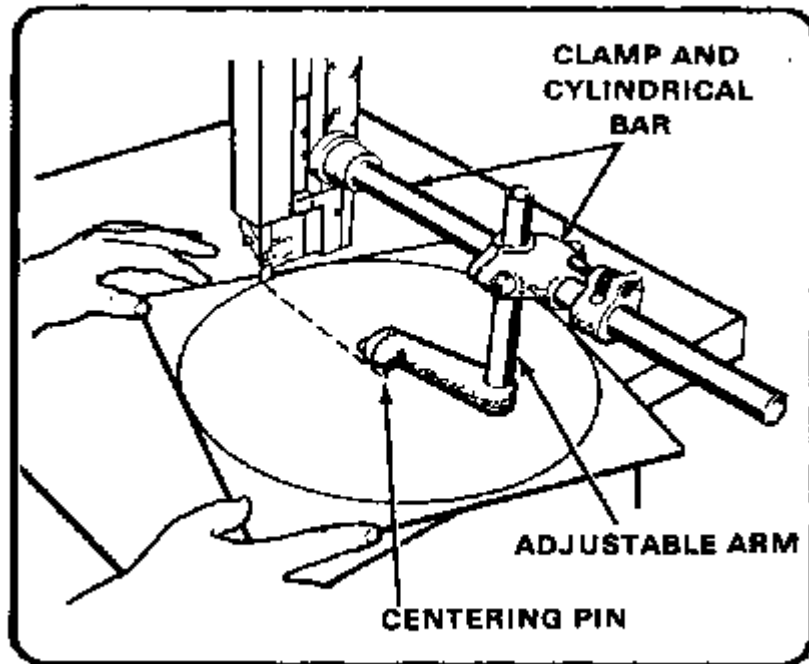

Figure 6-12. Disc-cutting attachment.

ANGULAR BLADE GUIDE ATTACHMENT

This attachment ([Figure 6-13](#)) twists the blade so that long workpieces that would not normally clear the machine column can be cut. The blade is twisted to a 30 degree angle on most machines.

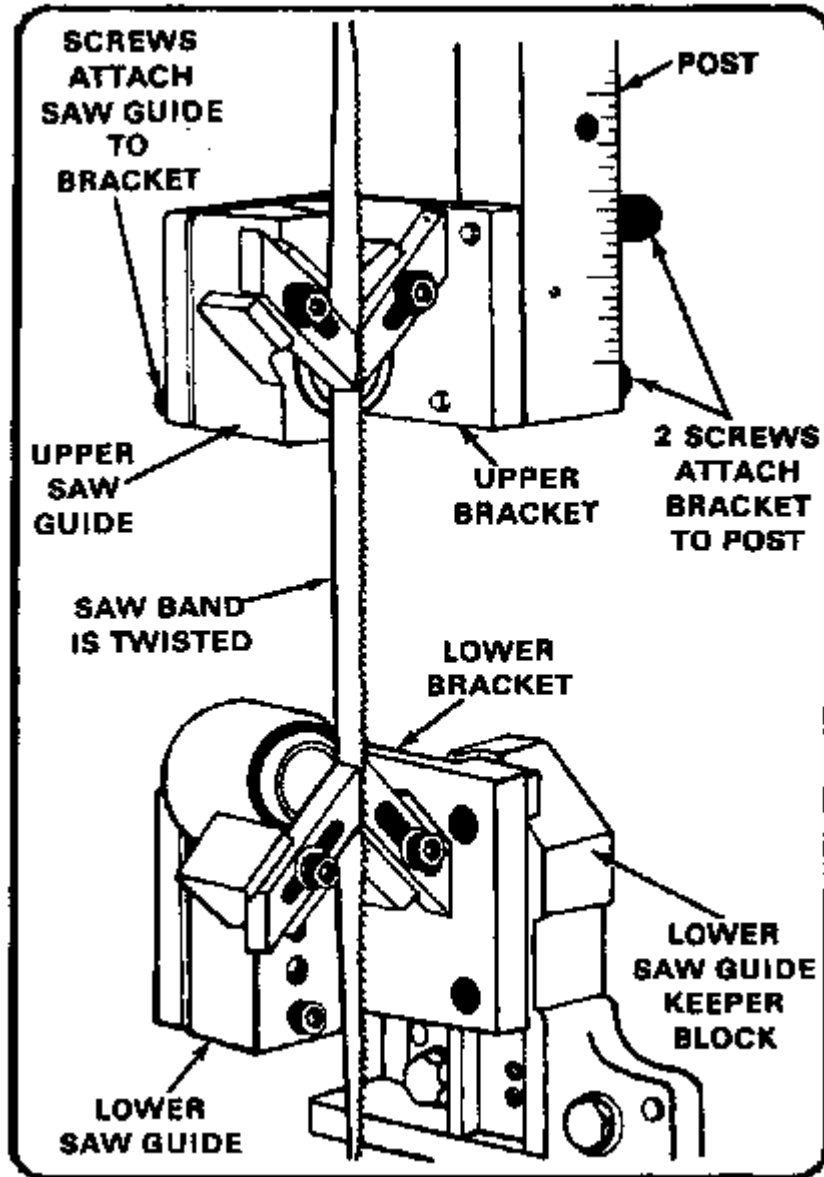

Figure 6-13. Angular saw guides.

MITER GUIDE ATTACHMENT

A typical miter guide attachment is illustrated in [Figure 6-14](#). The workpiece is supported against the miter head which attaches to the slide arm. The attachment can be set at an angle with a protractor, using the table slot as a reference line. A gage rod can be extended from the attachment and used as a stop when identical lengths are sawed. When not in use, swing the attachment on the slide rod so that it hangs below the table.

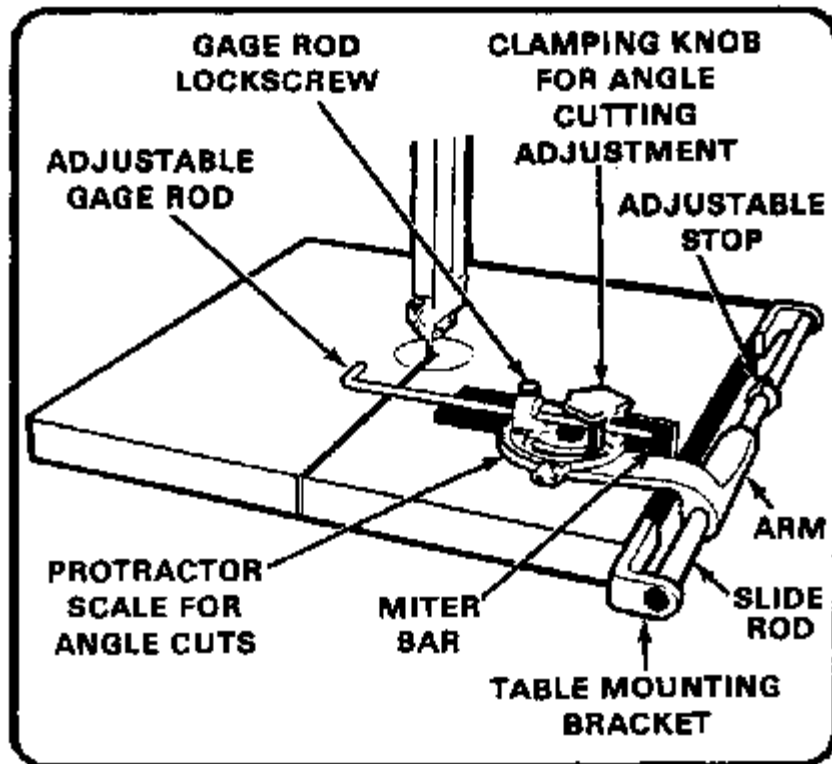

Figure 6-14. Miter guide attachment.

LAYING OUT AND MOUNTING WORK

POWER HACKSAWING

Layout

Power hacksaw machines are primarily intended for straight line cutting of stock to specific lengths. Laying out the workpiece consists of measuring the length to be cut and indicating the position for the cut by scribing a line on the stock.

Mounting

Before mounting the stock to be cut, the vise should be checked for squareness with the hacksaw blade. Place a machinist's square against the blade and the stationary vise jaw. Adjust the jaw, if necessary, at 90° to the blade. If the workpiece is to be cut at an angle other than 90°, loosen the vise and swivel it to the desired angle, measuring the angle carefully with a protractor.

Stroke

Move the blade frame and hacksaw blade by hand through one draw stroke and one return stroke. Observe whether the stroke is centered on the work and if the blade holders will clear the workpiece at the end of the stroke. Readjust the position of the vise if the stroke is not centered on the workpiece. Shorten the stroke if the blade holders hit the workpiece at the end of each stroke.

Stop gage

Use a stop gage to speed up mounting stock when several pieces of the same length are to be cut. Mount the first piece in the vise and align with the hacksaw blade to cut at the scribed line. When the workpiece is correctly positioned, move the stop gage up to the end of the workpiece and lock it in place. Cut subsequent pieces by moving the stock up to the stop gage and clamping the workpiece in the vise at this position.

Vise

The vise must be securely tightened on the workpiece to prevent loosening during cutting. Blade breakage might result from shifting workpieces not clamped tightly in the vise.

HORIZONTAL BAND SAWING MACHINES

The stock should be measured and the position of the cut machinist's square or a protractor against the bandsaw blade and the stationary vise jaw. Position the stock in the vise so that the saw blade aligns with the scribed line on the stock. If more than one piece is to be cut to the same size, move the stock stop arm against the end of the stock and lock it in place. Additional pieces can then be moved up against the stop to produce pieces equal in length to the first piece.

VERTICAL BANDSAWING MACHINES

When laying out workpieces for vertical bandsawing operations, consider the size of the stock in relation to the clearance of the bandsaw machine column. For straight-line sawing the clearance is easy to judge, but for contour sawing of large size stock, the directions of cut must be carefully figured to prevent the stock from hitting the column. If

a small section is to be cut from a large sheet of metal, the section should be roughly cut oversize from the sheet and then carefully cut to the prescribed outline.

CIRCULAR SAWING

When a circle or disk is to be sawed using the disk cutting attachment, lay out the circle on the stock as follows:

- Using a compass or pair of dividers, scribe a circle in the desired location and of the desired diameter on the stock.
- Center-punch and drill a center hole in the disk to accept the center pin of the disk cutting attachment. Make the hole only as deep and as large as required for the center pin; too large a hole will cause the center pin to fit loosely, which will result in an inaccurate cut.

CONTOUR SAWING

When an outline to be cut consists of more than two intersecting lines, the following procedure should be followed.

- Scribe the exact shape required on the stock. Take advantage of straight, clean edges on the uncut stock in laying out the piece to save unnecessary cuts.
- Determine the bandsaw blade size necessary to cut the smallest radius laid out on the workpiece
- Select a twist drill equal to or greater in diameter than the width of the bandsaw blade. Drill a hole in each corner of the pattern, making sure the holes fall within the section of material that will be removed. The corner sections are notched out after the piece is cut.
- If an internal section is to be removed from the stock and the edge must remain unbroken, layout and drill a starting hole ([Figure 6-15](#)) using a drill larger in diameter than the, width of the band saw blade. The bandsaw blade will be inserted through this hole before being welded into a band and installed on a bandsawing machine.

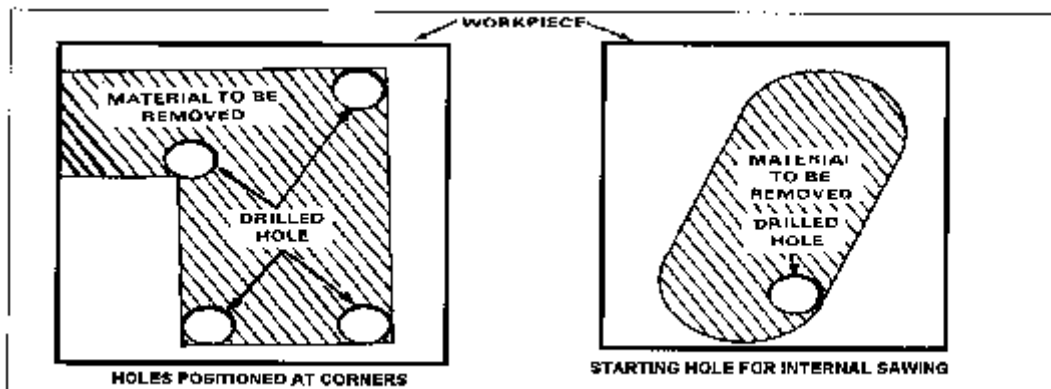

Figure 6-15. Hole layout for contour sawing.

GENERAL SAWING

Efficient sawing with sawing machines requires sharp saw blades in good condition. To prevent dulling and breakage of saw blades, proper speeds and feeds must be maintained. The speed of the saw blade for any specific operation depends upon the nature of the material being cut.

POWER HACKSAWING

Power hacksawing machines cut by drawing the hacksaw blade toward the motor end of the machine. At the completion of this movement called the draw stroke, the hacksaw blade is lifted slightly to clear the material being cut and moved an equal distance in the opposite direction.

Mounting Workpieces

Workpieces for metalcutting machines are not mounted to the machine, but are supported by the table of the machine and guided by one of the sawing machine attachments or by hand.

Power Hacksaw Speeds.

Since the cutting speed of hacksawing machines is measured in strokes per minuet, the length of the stroke is an important consideration. A longer stroke at a given speed will cut faster than a shorter stroke at the same speed. Thus, to obtain a proper cutting speed the length of the stroke must be specified.

The length of the stroke of most power hacksaws is between 4 and 10 inches depending upon the size of the machine. On machines with an adjustable stroke, the wider the stock being cut, the shorter the stroke to prevent the blade holders from hitting the stock.

With most power hacksaws, the stroke length is adjustable within 2 or 3 inches, and on some machines more than one speed can be selected. On single-speed hacksawing machines, the speed must be regulated by changing the stroke.

If the stroke is doubled the machine will cut twice as fast, and if the stroke is decreased by one-half, the machine will cut half as fast. This proportion can be applied to any fraction to increase or decrease the cutting speed of the machine.

The speeds given in the chart, [Figure 6-16](#), bellow are for example only. The correct speeds for cutting various metals will depend on the type of machine you are using. In general the faster speeds are used for cutting soft materials and the slower speeds are used for cutting harder materials. If a recommended speed cannot be approximated either by changing the stroke or changing the speed, the feed can be decreased to prevent undue wear to the hacksaw blade.

MATERIAL	SPEED IN STROKES PER MINUTE	
	4 TO 6 INCH	8 TO 10 INCH
ALUMINUM	135	65
BRASS	135	65
BRONZE	90	45
CAST IRON	90	45
COPPER	135	65
STEEL, ALLOY	90	45
STEEL, HIGH-SPEED	60	30
STEEL, MACHINE	135	65
STEEL, STAINLESS	60	30
STEEL, TOOL (ANNEALED)	90	45
STEEL, TOOL (UNANNEALED)	60	30

Figure 6-16. Power hacksawing machine speeds.

Power hacksaw machines having a mechanical feed can usually be regulated to feed the saw downward from 0.001 to 0.025 inch per stroke, depending upon the type and size of the material to be cut. On these machines, a device to stop the feed when hard spots are encountered is usually incorporated into the design.

The feed of machines having gravity feed is regulated by the weight of the saw frame and any additional weights or springs that might be connected or attached to the frame to increase or decrease the downward force of the hacksaw blade. Maximum and minimum blade pressures obtainable are determined by the manufacturer of the hacksawing machine, and are specified as relatively light or heavy.

The following general rules apply for selecting proper feeds for hacksawing machines:

- The feed should be very light when starting a cut and can be increased after the cut is well started.
- Hard materials require a lighter feed than soft materials; reduce the feed when welds or hard spots in materials are encountered.
- Wide material requires a heavier feed than narrow material because the pressure is distributed over a larger surface.
- Sharp hacksaw blades will cut well with lighter feeds. Heavier feeds are necessary for cutting with dull blades.

BANDSAWING

The cutting speed of the bandsaw machine is the speed of the bands blade as it passes the table measured in feet per minute. The feed of the horizontal band saw machines downward pressure applied to the material being cut by the bands blade. The feed of vertical bandsawing machines is the pressure applied to the bands blade by the material being cut.

Bandsawing Speeds

Proper bandsaw speeds are important in conserving bands blades. Too great a speed for the material being cut will cause abnormally rapid blade wear, while too slow a speed will result in inefficient production. The chart of recommended speeds (Figure 6-17) are guidelines only. It shows the speeds for a given type of machine. The cutting speed always depends on the type of machine you are using and the manufactures' recommendations.

MATERIAL	BANDSAWING SPEED (fpm)	MATERIAL	BANDSAWING SPEED (fpm)
ALUMINUM	200 TO 2,000	RUBBER, HARD	150 TO 250
BAKELITE	200 TO 800	STEEL, ALLOY	50 TO 100
BRASS, SOFT	175 TO 300	STEEL, HIGH CARBON ...	50 TO 100
BRASS, HARD	75 TO 150	STEEL, HIGH-SPEED	50 TO 90
BRASS, SHEETS	200 TO 800	STEEL, MACHINE	75 TO 175
BRONZE	75 TO 150	STEEL, SHEET	150 TO 200
CAST IRON	50 TO 100	STEEL, STAINLESS	50 TO 75
COPPER	115 TO 175	STEEL, TOOL	50 TO 150
MONEL METAL	50 TO 100		

Figure 6-17. Band sawing speeds.

All bandsawing machines have several cutting speeds. Since the diameter of the drive wheel of the bandsaw machine establishes a fixed ratio between the motor or transmission speed in RPM to the blade speed in FPM, it is not necessary to convert RPM into FPM as with most other machine tools. The speeds are identified in FPM on the sawing machine speed selector controls. Some machines have a speed indicator so a careful check of sawing speeds may be made when the machine is operating with or without a load.

In general the following principles apply to speeds of bandsaw blades:

- The harder the material, the slower the speed; conversely, the softer the material, the faster the speed.
- The faster the speed, the finer the finish produced on the cut surface. This principle applies to light feeds in conjunction with fast feeds.

Horizontal Bandsawing Machine Feeds

Feed of horizontal bandsaw machines is controlled by adjusting the pressure applied by the saw blade against the material being cut, as with hacksawing machines.

The horizontal saw has a spring counterbalance and a sliding weight to adjust the pressure of the blade. When the sliding weight is moved toward the pivot point of the saw frame the band saw blade pressure is reduced. When the weight is moved away from the pivot point, the pressure is increased.

The following general principles apply when regulating the feed of horizontal band saw machines.

- The feed should be very light when starting a cut. After the cut is started, increase the feed.
- Wider material requires a heavier feed than narrow material.
- Wide blades will stand greater pressure than narrow blades and can therefore be used with heavier feeds.
- A lighter feed is required for hard materials; a heavier feed can be used for soft materials.
- Reduce the feed when hard spots in the material are encountered such as chilled spots in cast iron and welds in joined sections.

Vertical Machine Feeds

With vertical machines, the feed is the pressure applied to the saw blade by the material being cut. The workpiece may be hand fed or power fed depending upon the operation to be performed. Cutting curves or special contours requires that the workpiece be guided and fed into the saw blade by hand.

The power feed on bandsaw machines is operated by adjustable weights in the machine pedestal. The weights are connected by cables to one of the work-holding attachments of the sawing machine to pull the workpiece against the bandsaw blade. To operate the power feed, the weights are raised by depressing a pedal and the cables are then fixed to the work-holding attachment. When the pedal is released the weights pull the piece into the blade.

The following general rules apply to feeding workpieces on bandsawing machines:

- The feed should be light when starting a cut. The pressure can be increased after the cut is established.
- Hard materials require lighter feeds than softer materials.
- Wider band saw blades will stand greater pressure than narrow blades and can therefore be used with heavier feeds.
- When hard spots in the material being cut are encountered, reduce the feed until the spots are cut through.
- Use a light feed when cutting curves; a heavier feed for straight-line cutting.

COOLANTS

Most sawing machines used in military operations are dry cutting machines; that is, they are not intended for use with liquid coolants. However, some power hacksaws and horizontal bandsaws are equipped with a coolant attachment. Soluble oil products, when mixed with water to form emulsions, are used for these machines. This type of coolant has proven very satisfactory for sawing where cooling is an important factor. Most

manufacturers of water oil emulsion coolants add a rust inhibitor to the solution to prevent rusting caused by the water in the coolant.

STRAIGHT-LINE SAWING

Straight-line sawing is the most common machine sawing operation. It may be performed using the power hacksaw, horizontal, or vertical band saw.

Power Hacksawing

The power hacksaw machine is designed primarily for straight-line sawing. A typical sawing operation is outlined below:

- Select a hacksaw blade of the proper length for the machine and proper pitch for the material to be cut. Install the hacksaw blade with the teeth pointing downward and toward the motor end of the hacksawing machine.
- Check the alignment of the vise and hacksaw blade and mount the workpiece in the vise. Make sure the vise holds the workpiece securely.
- Check the stroke of the hacksawing machine and adjust if necessary. After adjusting the stroke, move the hacksaw blade and sawing machine frame through one cycle (draw stroke and return stroke) by hand to check the blade clearance at each end of the workpiece. Readjust the position of the vise if necessary.
- Position the hacksaw blade about 1/4 inch above the workpiece and set the feed control to its lightest feed setting.
- Set the desired speed of the hacksawing machine.
- Start the machine and let the blade feed lightly into the workpiece for about 1/4 inch. Readjust the feed to whatever the material will stand for normal cutting.
- Permit the hacksaw blade to cut completely through the workpiece. The blade frame will trip a switch on the sawing machine bed to stop the sawing machine.

Horizontal Bandsawing

Like hacksawing machines, the horizontal bandsaw machine is used primarily for straight-line sawing. The typical sequence of operation for this machine is outlined next.

- Select and install a bandsaw blade of the proper pitch for the type and size of material to be cut.
- Set the vise to the desired angle and check the angle by measuring it from the line of the band saw blade.
- Mount the workpiece in the vise. Make sure the work piece is secured and will not loosen during cutting.
- Check the alignment of the blade guides for vertical positioning and adjust if necessary.
- Position the saw frame so that the bandsaw blade is 1/4 inch above the workpiece. The power feed weight should be placed at its lightest feed setting.
- Set the desired speed on the horizontal band sawing machine.

- Start the machine and let the bandsaw blade cut into the workpiece about 1/4 inch. After the cut has been established, readjust the feed weight to exert the desired amount of pressure on the workpiece.
- The machine will stop itself when it cuts completely through the workpiece.

Vertical Band Saw Operation

Straight-line sawing is performed on the vertical band saw machine by using one or a combination of several mechanisms or attachments: the miter guide attachment, with or without power feed, with or without the work-holding jaw device-. and the work-holding jaw device with power feed and angular blade guide attachment.

- The miter guide attachment on some machines can be connected to the power feed mechanism and on others must be fed by hand. The workpiece is clamped or hand-held against the miter guide attachment and the workpiece and attachment are moved on a track parallel to the blade, thereby assuring a straight-line cut.
- The work-holding jaw device on some machines can be connected to the power feed to produce straight-line cuts ([Figure 6-18](#)).
- The angular blade guide attachment is used for straight-line sawing when the workpiece cannot be cut in the usual manner because it is too large or too long to clear the column of the bar, sawing machine frame.

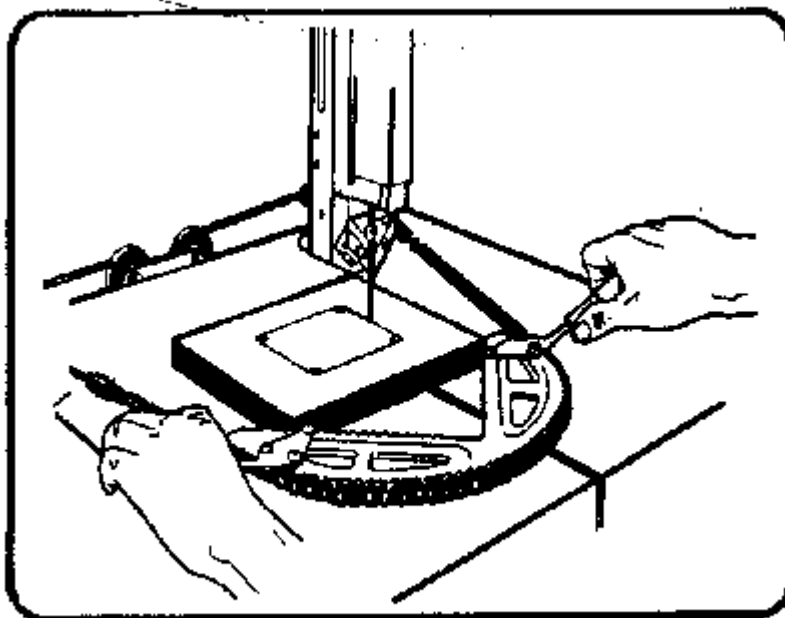

Figure 6-18. Work holding jaw device used for straight-line sawing with power feed.

A typical example of straight-line sawing is outlined below :

- Select a band saw blade of the desired pitch for the nature of material to be cut. The blade should be as wide as possible for straight-line sawing.
- Set the desired speed on the bandsawing machine.
- Position the workpiece at the desired angle in one of the machine attachments and connect the cable to the power feed mechanism if power feed is to be used.
- Start the bandsawing machine and feed the workpiece lightly into the blade to start the cut. Once the cut is started, the feed can be increased. If feeding is by hand, the pressure applied to the workpiece by the operator can be varied to find the best cutting conditions.

RADIUS SAWING

Radius sawing is performed on the bandsaw by either guiding the workpiece by hand or by using the disk-cutting attachment.

Blade Selection

Care must be taken to select a bandsaw blade of the proper width for the radius or circle to be cut. If the blade is too wide for the radius, the heel of the blade will press against the outer edge of the kerf ([Figure 6-19](#)). When the heel contacts this edge, any further twisting of the workpiece in an attempt to cut a sharper radius will twist the bandsaw blade and may result in the blade breaking.

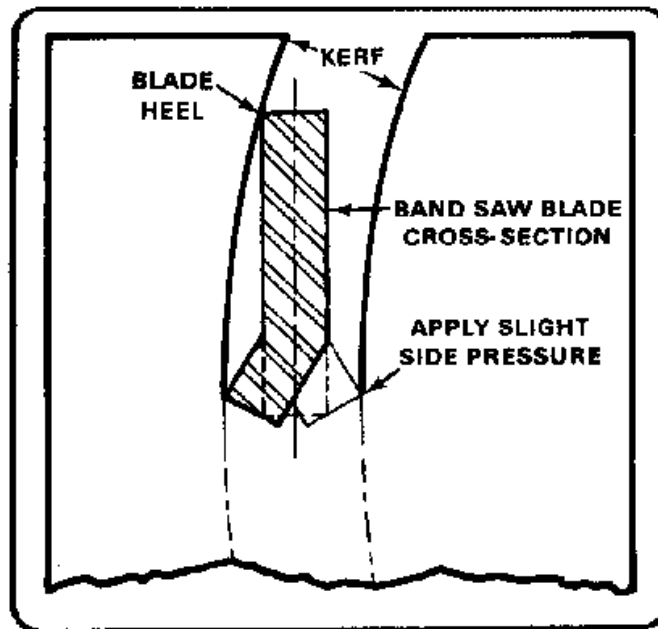

Figure 6-19. Radius limitation for bandsaw blade.

Cutting Pressure

When cutting a radius, apply a slight side pressure at the inner cutting edge of the bandsaw blade ([Figure 6-19](#)). This pressure will give the blade a tendency to provide additional clearance.

CONTOUR SAWING

Contour sawing is the process of cutting shapes in which the direction of the cut must be changed at intervals. Holes larger in diameter than the width of the saw blade must be drilled at each corner where a change of direction of the bandsaw blade will occur. [Figure 6-20](#) illustrates the methods of changing direction of a cut at a hole.

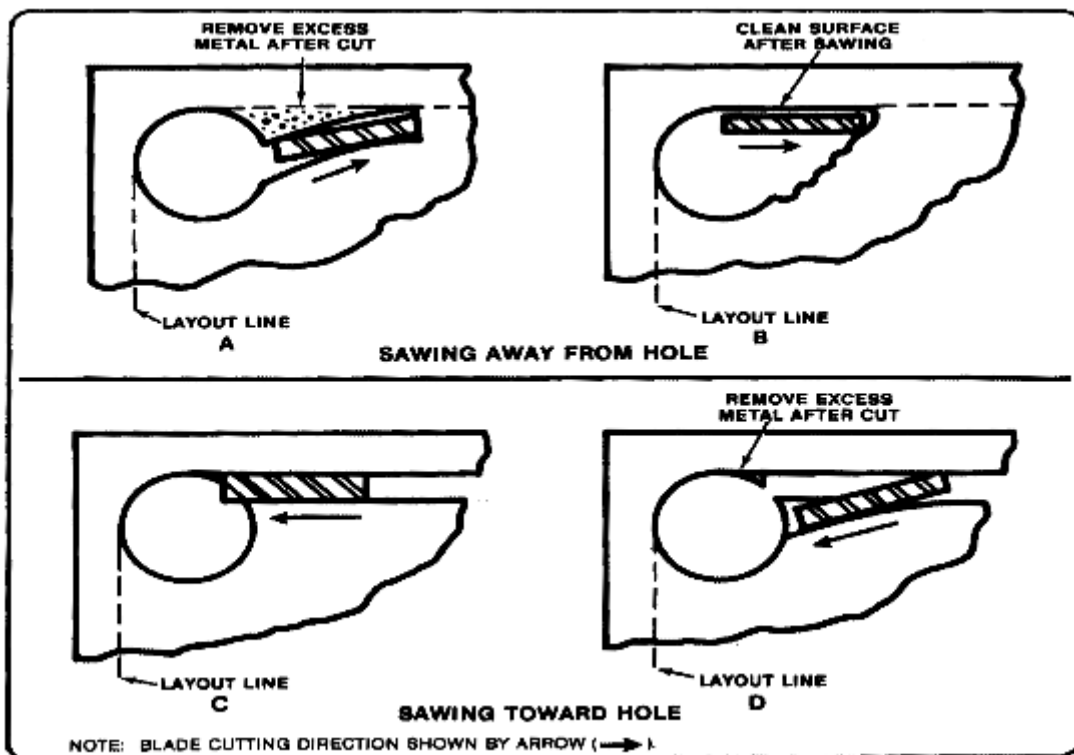

Figure 6-20. Methods of sawing to and away from holes.

Sawing Away From the Hole

To saw away from the hole on a line tangent to the hole, the saw blade must cut away from the center of the hole, or the blade will bow and cause a belly in the cut. The cut should be started as in A, [Figure 6-20](#), in which a curve is cut outward from the hole to meet the layout line, leaving a piece of excess metal which can be removed later by filing. An alternate method is shown at B, [Figure 6-20](#), in which a section of metal is notched out with a saw blade by several short cuts to give the blade clearance for starting the cut along the layout line.

Sawing Toward the Hole

The diagrams at C and D, [Figure 6-20](#), show the proper method of sawing up to a hole in two cuts. The excess metal can be removed later by filing. After the shape is cut and the slug or waste material is removed, the comers should be finished by filing or notching. The bandsaw blade should not be used for these operations because the blade will bow and cut unevenly.

SPECIAL OPERATIONS ON SAWING MACHINES

INTERNAL SAWING

Internal sawing is performed in the same manner as contour sawing except that the bandsaw blade cannot start cutting from the edge of the workpiece but must start cutting from a drilled hole in the workpiece ([Figure 6-20](#)). With the pattern laid out on the workpiece and the starting hole drilled, insert an unwelded bandsaw blade of the proper length through the starting hole. Bring the two ends of the blade together at the butt welder of the bandsawing machine and weld the blade into a continuous band as described in the pertinent operation manual for the machine. Install the bandsaw blade on the sawing machine and make the necessary adjustments to the machine. With the cut starting from the hole as shown in A or B, [Figure 6-20](#). When the sawing is completed, cut the bandsaw blade so that it can be removed from the workpiece.

BAND FILING

Filing is performed on the vertical band saw machine using a band file and the band file attachment. As with sawing, the quality of filing and the economical wear of the band file depend upon proper selection of files and filing speeds for different materials and conditions.

Band Filing Speed

Band files should be run at relatively slow speeds as compared to speeds used for band sawing. [Figure 6-21](#) lists recommended speeds for band filing. Note that, in general, the slower speeds are used for filing harder metals and faster speeds are used for filing softer metals.

MATERIAL	BAND FILING SPEED (fpm)	MATERIAL	BAND FILING SPEED (fpm)
ALUMINUM	75 TO 176	FIBER	115 TO 175
BRASS	115 TO 260	MAGNESIUM	75 TO 175
BRONZE	75 TO 115	STEEL, ALLOY	50 TO 115
CAST IRON	50 TO 115	STEEL, MACHINE	75 TO 175
COPPER	115 TO 260	STEEL, TOOL	50 TO 75

Figure 6-21. Band filing speeds.

Band Filing Feeds

Work pressure on the band file should not be excessive. A medium amount of pressure applied against the band file moving at the proper speed will produce curled chips which will not clog the file. Heavy pressure will cause clogging and can cause the file to break or the machine to stall. A light pressures should be used for finish filing, with a slow, sideways motion that will not leave vertical file marks on the workpiece.

POLISHING

Polishing bands and a polishing attachment are provided with the vertical band saw machine so that light polishing can be performed. The polishing bands are intended primarily for removing saw marks on the cut edges of workpieces.

Polishing Speeds

Move polishing bands at speeds between 75 and 260 FPM, the faster speeds being used for softer materials and the slower speeds being used for harder materials.

Polishing Feeds

Feeds should be light for polishing. Use a slow, sideways motion so that the polishing band will leave no marks on the workpiece. If the band does not remove the tool marks quickly, change to a coarser polishing band.